

HINGE OPEN 180°
ISOMETRIC VIEW

.156" DIA WITH
9/32" DIA x 82° C'SINK

7/64" DOOR CLEARANCE

WOOD SCREW
#6 x 1"

MACH. SCREW
#6-40 x 1/2"

HINGE OPEN 180°
FRONT VIEW

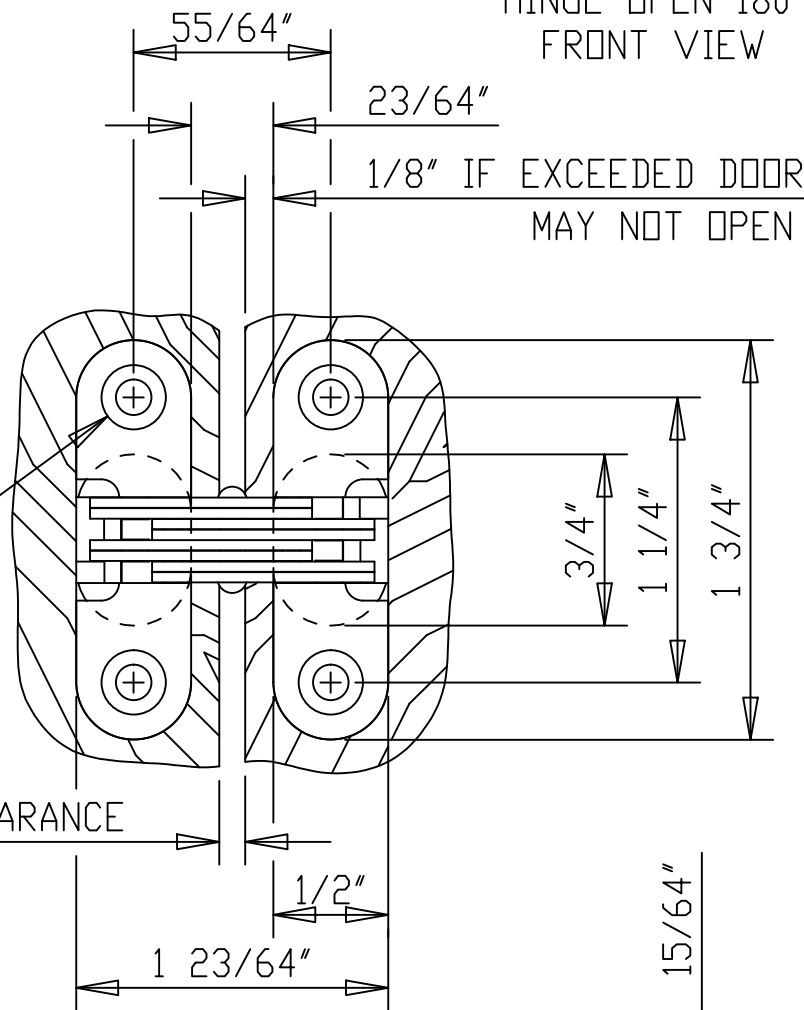

HINGE OPEN 180°
TOP VIEW CUT AWAY

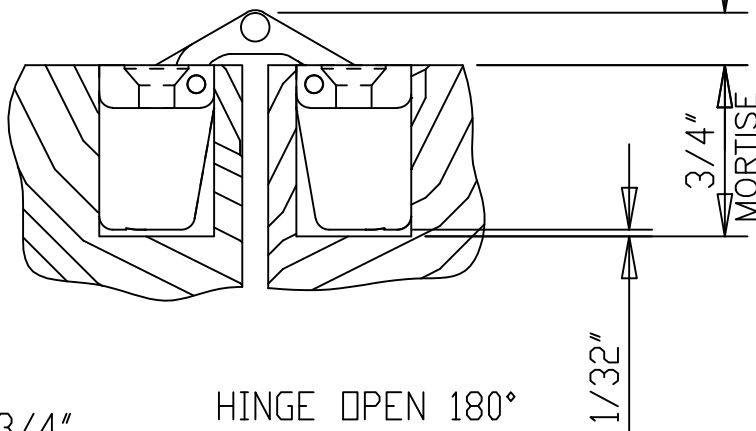

HINGE CLOSED
FRONT VIEW CUT AWAY

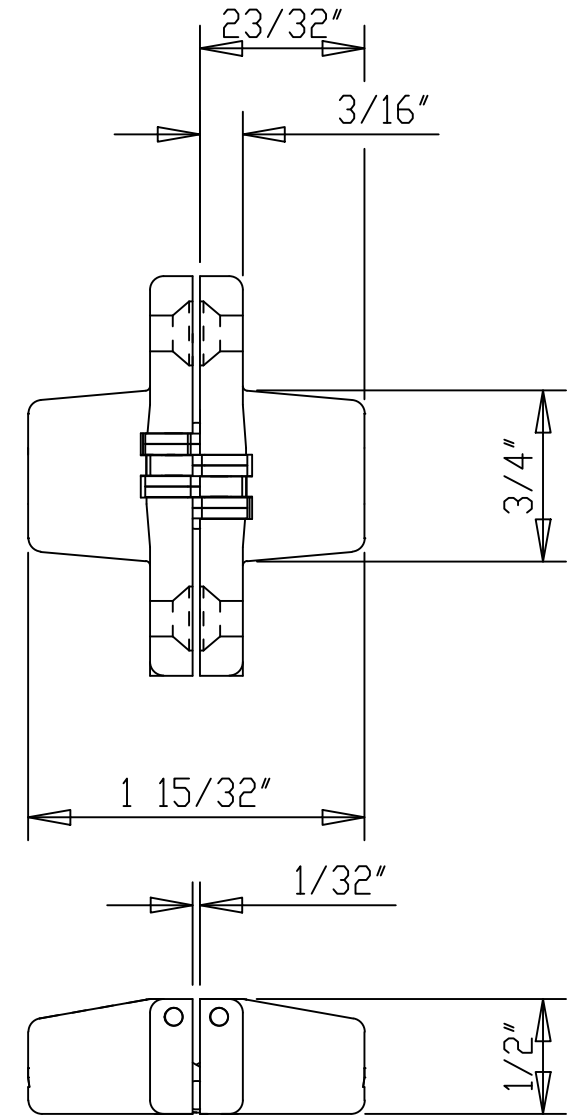

HINGE CLOSED
TOP VIEW CUT AWAY

 ©Copyright 2008 Universal Industrial Products, Inc. One Coreway Drive Pioneer, Ohio 43554-0628	SCALE: 1 = 1
	DRAWN BY: LHH
HINGE TEMPLATE	DATE: 5/01/11
#203 SOSS INVISIBLE HINGE	DRAWING # 203

MIN. MATERIAL THICKNESS IS 3/4"
DO NOT SCALE DRAWING
ALL DIMENSIONS ARE IN INCH
DOOR CLEARANCE REDUCES TO 1/64" WHILE CLOSING
SEE DWG# 4477-C IF ADDING MATERIAL TO DOOR FACE AND/OR FRAME FACE